

LCS linear conveying system

AAE manufactures a high-tech linear conveying system, where based on standard concepts a wide variety of transfer systems can be built. Thanks to the unique construction and the various drive systems, the LCS systems represent the latest developments in speed and accuracy. The LCS transfer systems (Linear Conveying System) is based on the combination of the following precision components (see picture 1).

- Sturdy alloy aluminium chain links, CNC machined from solid billets with 4-fold bearing support. (see position 1 and picture 2)
- Extruded track guide over the full straight length, with integrated steel guides. (see position 2)
- Aluminium centre frame with universal mounting slots. (see position 3)
- Steel sprocket rings. (see position 4)

Options

Based on the standard components as described above, the LCS transfer system can be tailored to meet your specific requirements. Possibilities here are for instance:

- Motor drive : servomotors, AC motors, indexing systems and manifolds; The LCS transfer system can be used for indexing systems and continuous motion alike. (see position 5)
- Product carrier : specific product carriers for round, rectangular or odd-shaped products. (see position 6)
- Length of the LCS transfer system.

Advantages

Compared to standard chain systems, the LCS transfer system offers you some remarkable advantages:

- Very robust construction.
- Sturdy, stable chain with minimum of free play.
- Automatic free play correction in case of greater length.
- Modular construction that can be tailored to any specific customer requirements.
- The central frame is fitted with universal mounting slots. All required components can be easily fitted and adjusted. The LCS linear transfer system can be perfectly combined with other AAE components.

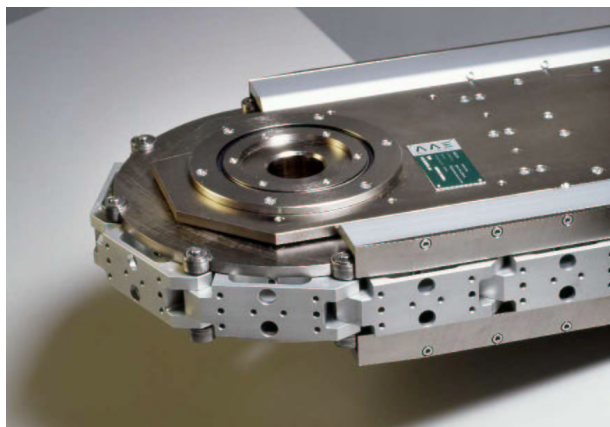

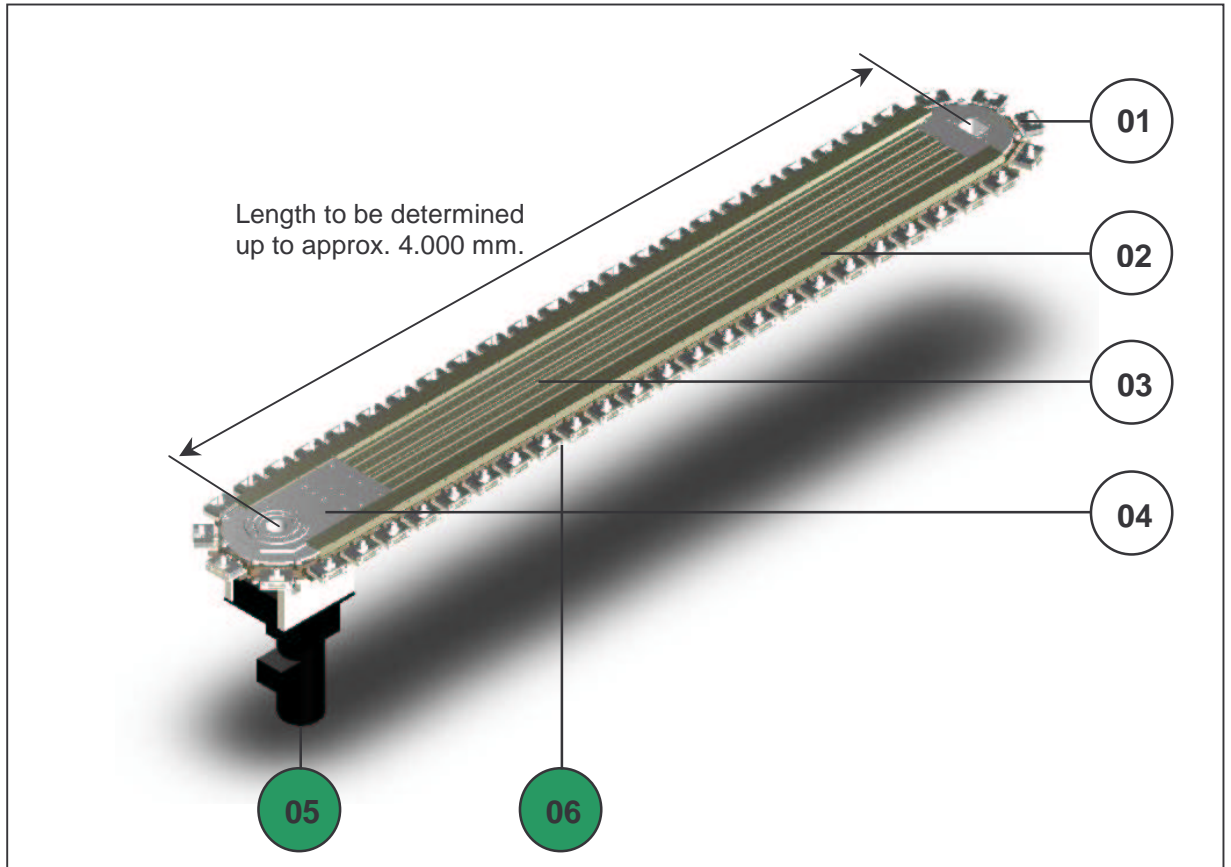

Picture 1 : Standard components combined with customer specific parts. (position 5 and 6).

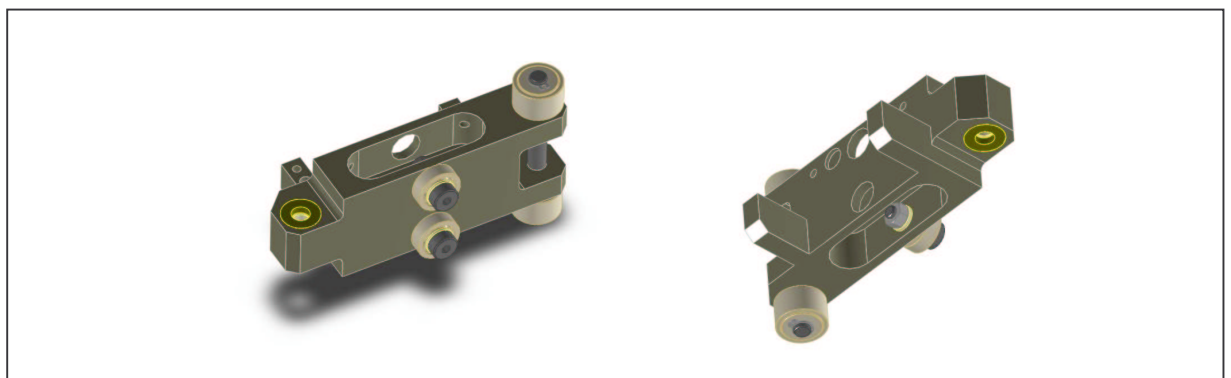

Picture 2 : Universal chain links with 4-fold bearing support. Very robust, CNC machined from billet alloy aluminium..